

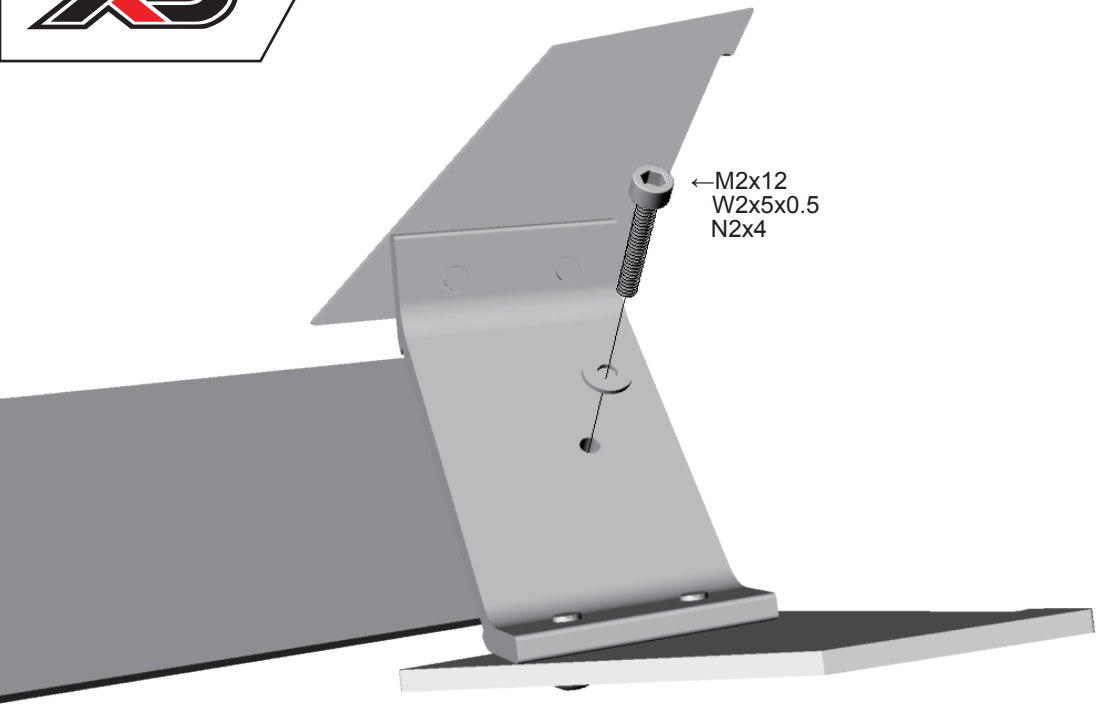

Frame assembly 機體組裝



←M2x12
W2x5x0.5
N2x4



3 Blade Rotor Head 3葉主旋翼頭

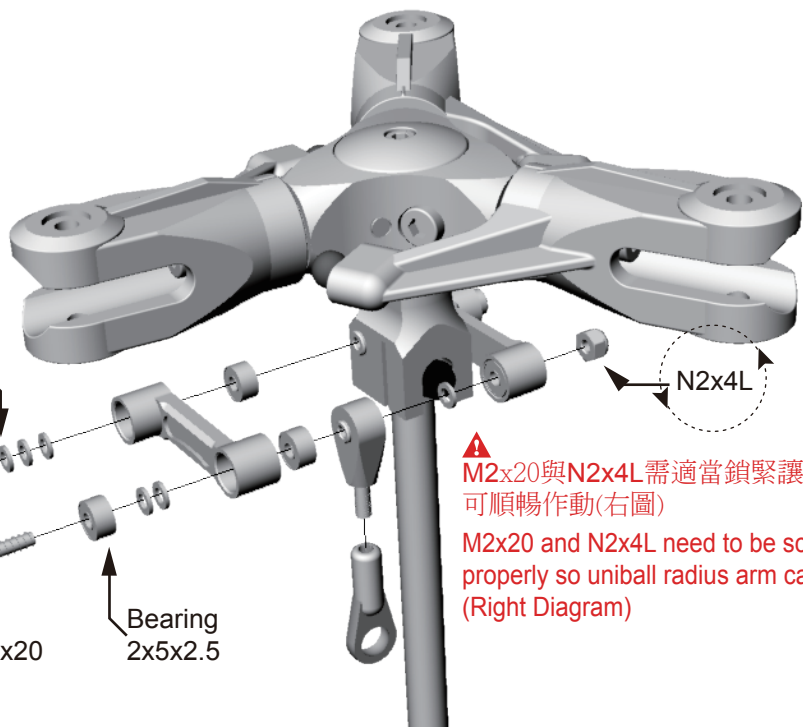

W2x3.5x0.5

M2x10

▲M2x20

Bearing
2x5x2.5

N2x4L

▲M2x20與N2x4L需適當鎖緊讓剪型臂推座可順暢作動(右圖)

M2x20 and N2x4L need to be screwed properly so uniball radius arm can move freely. (Right Diagram)

剪型臂推座
uniball radius arm

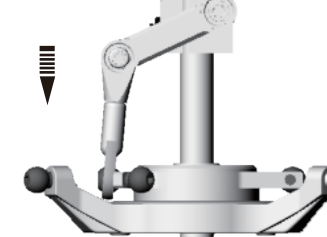
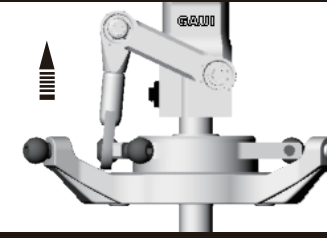
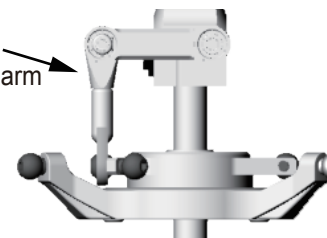



Tail push rod

尾拉桿

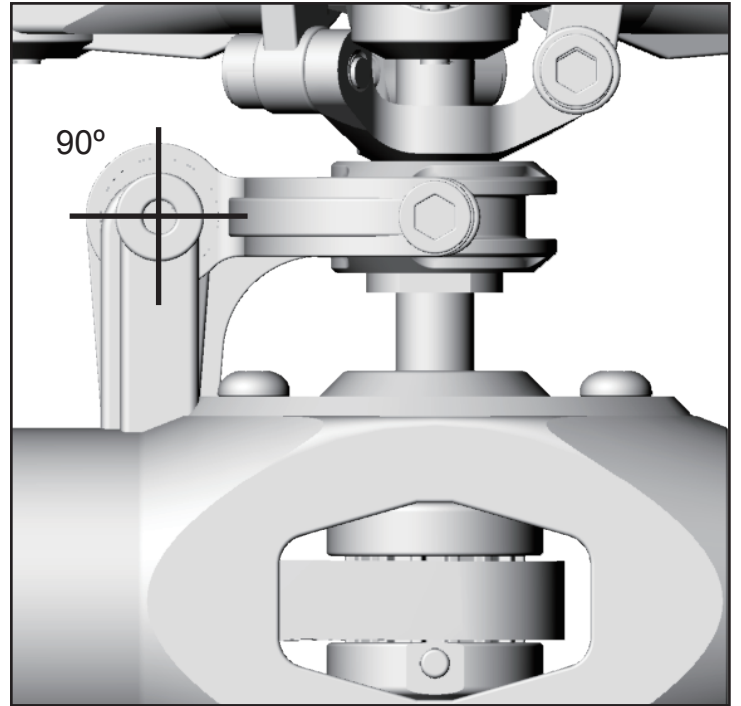
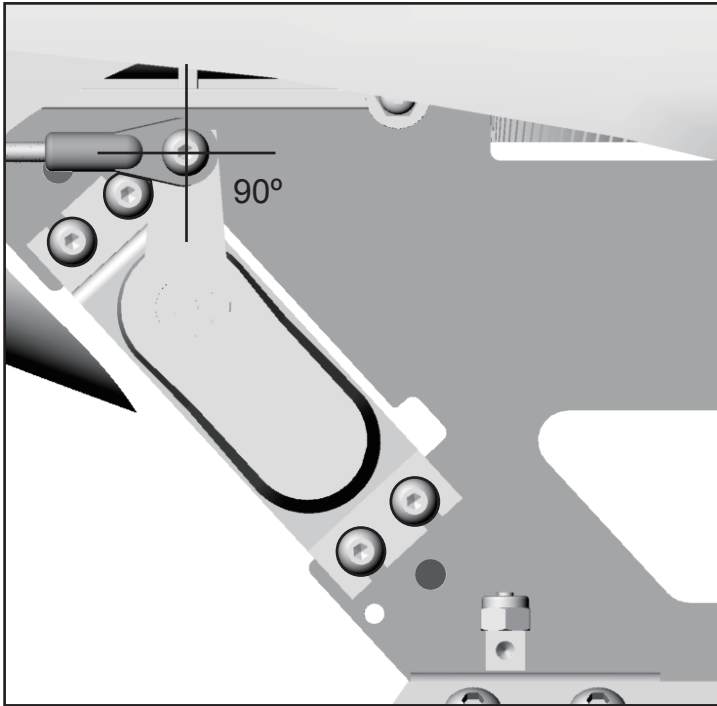

Electronics installation 電裝配置

